

# Brake Calipers EV 038 FEM and EH 038 FEM

spring activated – electromagnetically released



## Features

Features	Code
Brake Caliper with electromagnet	E
Mounting to the machine parallel or at right angles to the brake disc	V H
Frame size 038	038
Spring activated	F
Electromagnetically released	E
Manual adjustment to accommodate friction block wear	M
Supply voltage 220 to 240 VAC	240
Supply voltage 380 to 480 VAC	480
Electromagnet mounted in central position	M
Thickness of brake disc 12,5 ... 20 mm	12
or 22 ... 30 mm	25

## Example for ordering

Brake Caliper EV 038 FEM, supply voltage 400 VAC, electromagnet mounted in central position, thickness of brake disc 25 mm:

EV 038 FEM - 480 M - 25

## Advantages

The brake caliper EV 038 FEM or EH 038 FEM is a very compact and high efficient disc brake with very low power consumption. Its floating bearing compensates small misalignments of the brake disc. The attached electronic reduces the power consumption in open position automatically.

## Options

- Available with cCSAus approval
- Inductive proximity switch: "Brake released"-, "Brake closed"-status and/or "Friction block wear adjustment necessary"

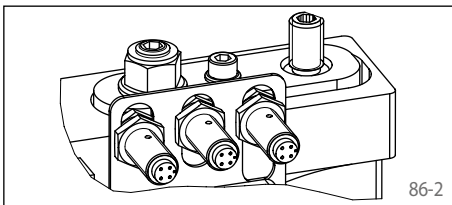

## Technical Data

	Brake Calipers EV 038 FEM and EH 038 FEM with supply voltage	
	220 to 240 VAC	380 to 480 VAC
Brake disc diameter	Braking torque	Braking torque
mm	Nm	Nm
430	2830	
520	3550	
630	4430	
710	5070	
800	5790	
900	6590	
Clamping force	20000 N	
Response time*	300 ms	
Clamping force or braking torque adjustable	60 - 100%	
Power consumption in open position	20 W	24 W
	(100% duty factor)	
Power when opening the brake (< 1 s)	2100 W	2300 W
Fuse rating	10 A, Type "B"	
Max. number of actuation	360/h permanent activations at 20° C ambient temperature	
Actuation frequency**	at least 8 seconds between 2 activations	
Weight	50 kg	

The braking torques shown in the diagram are based on a theoretical friction coefficient of 0,4.

\* The response time is the duration from switching off the power supply to reaching 80% of the maximum clamping force (at Ta = 20 °C, setting: 100%).

\*\* Shorter actuation frequency on request

# Brake Calipers EV 038 FEM and EH 038 FEM

spring activated – electromagnetically released

## Brake Caliper EV 038 FEM

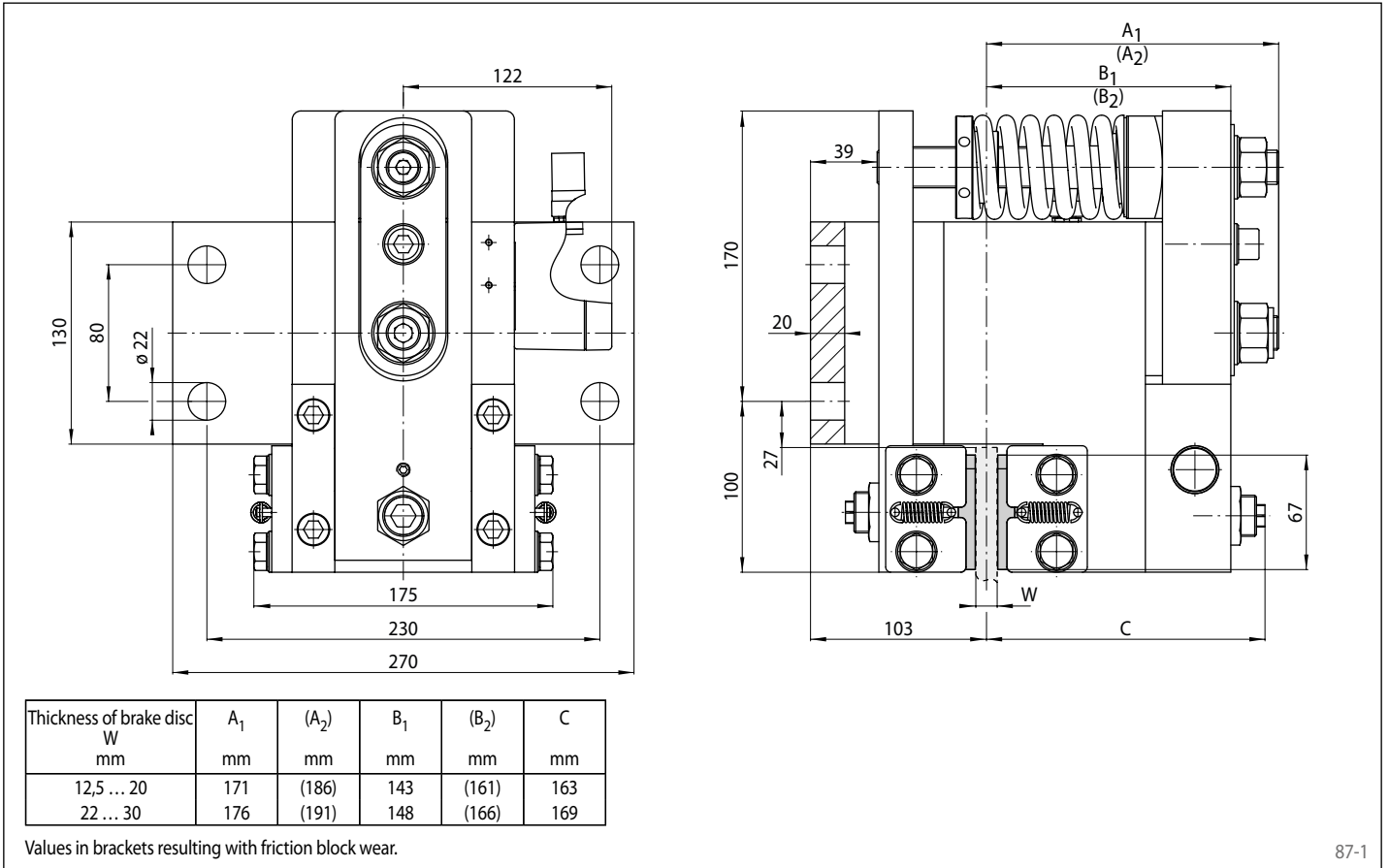

87-1

## Brake Caliper EH 038 FEM

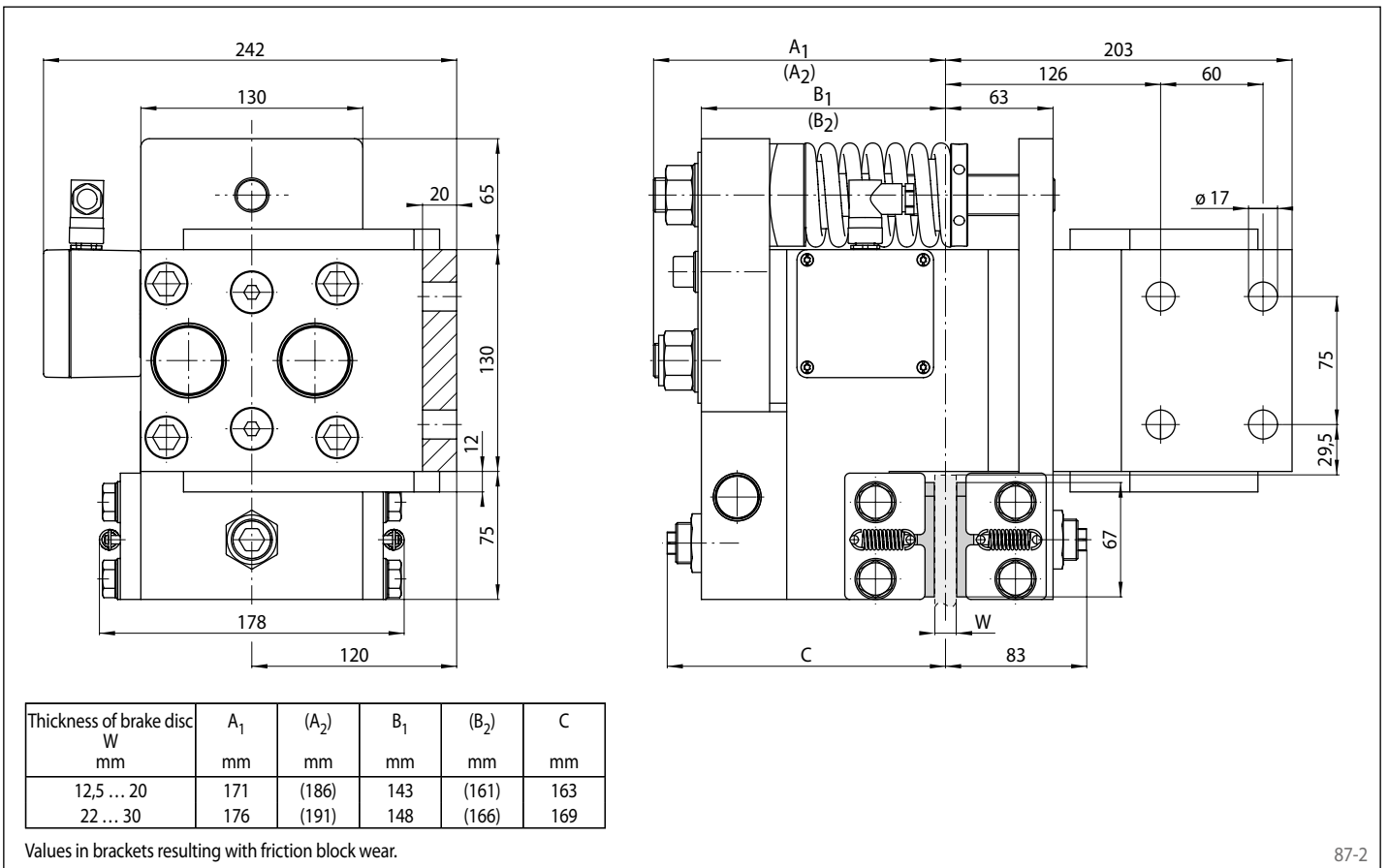

87-2