

Brake Calipers EV 028 FEM and EH 028 FEM

spring activated – electromagnetically released



Features

Features	Code
Brake Caliper with electromagnet	E
Mounting to the machine parallel or at right angles to the brake disc	V H
Frame size 028	028
Spring activated	F
Electromagnetically released	E
Manual adjustment to accommodate friction block wear	M
Supply voltage 220 to 240 VAC	240
Supply voltage 380 to 480 VAC	480
Electromagnet mounted in central position	M
Thickness of brake disc 10 ... 16 mm	12
or 18 ... 26 mm	25

Example for ordering

Brake Caliper EV 028 FEM, supply voltage 400 VAC, electromagnet mounted in central position, thickness of brake disc 15 mm:

EV 028 FEM - 480 M - 12

Advantages

The brake caliper EV 028 FEM or EH 028 FEM is a very compact and high efficient disc brake with very low power consumption. Its floating bearing compensates small misalignments of the brake disc. The attached electronic reduces the power consumption in open position automatically.

Options

- Available with cCSAus approval
- Inductive proximity switch: "Brake released"-, "Brake closed"-status and/or "Friction block wear adjustment necessary"

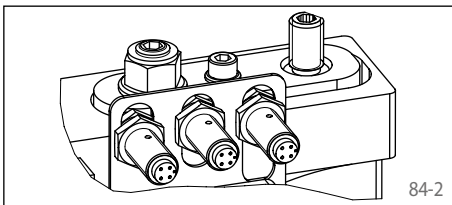

Technical Data

	Brake Calipers EV 028 FEM and EH 028 FEM with supply voltage	
	220 to 240 VAC	380 to 480 VAC
Brake disc diameter	Braking torque	Braking torque
mm	Nm	Nm
300	940	
355	1 160	
430	1 460	
520	1 820	
630	2 260	
710	2 580	
Clamping force	10 000 N	
Response time*	150 ms	
Clamping force or braking torque adjustable	60 - 100%	
Power consumption in open position	15 W	19 W
	(100% duty factor)	
Power when opening the brake (< 1 s)	1 850 W	2 500 W
Fuse rating	10 A, Type "B"	
Max. number of actuation	360/h permanent activations at 20° C ambient temperature	
Actuation frequency**	at least 8 seconds between 2 activations	
Weight	24 kg	

The braking torques shown in the diagram are based on a theoretical friction coefficient of 0,4.

* The response time is the duration from switching off the power supply to reaching 80% of the maximum clamping force (at Ta = 20 °C, setting: 100%).

** Shorter actuation frequency on request

spring activated – electromagnetically released

Brake Caliper EV 028 FEM

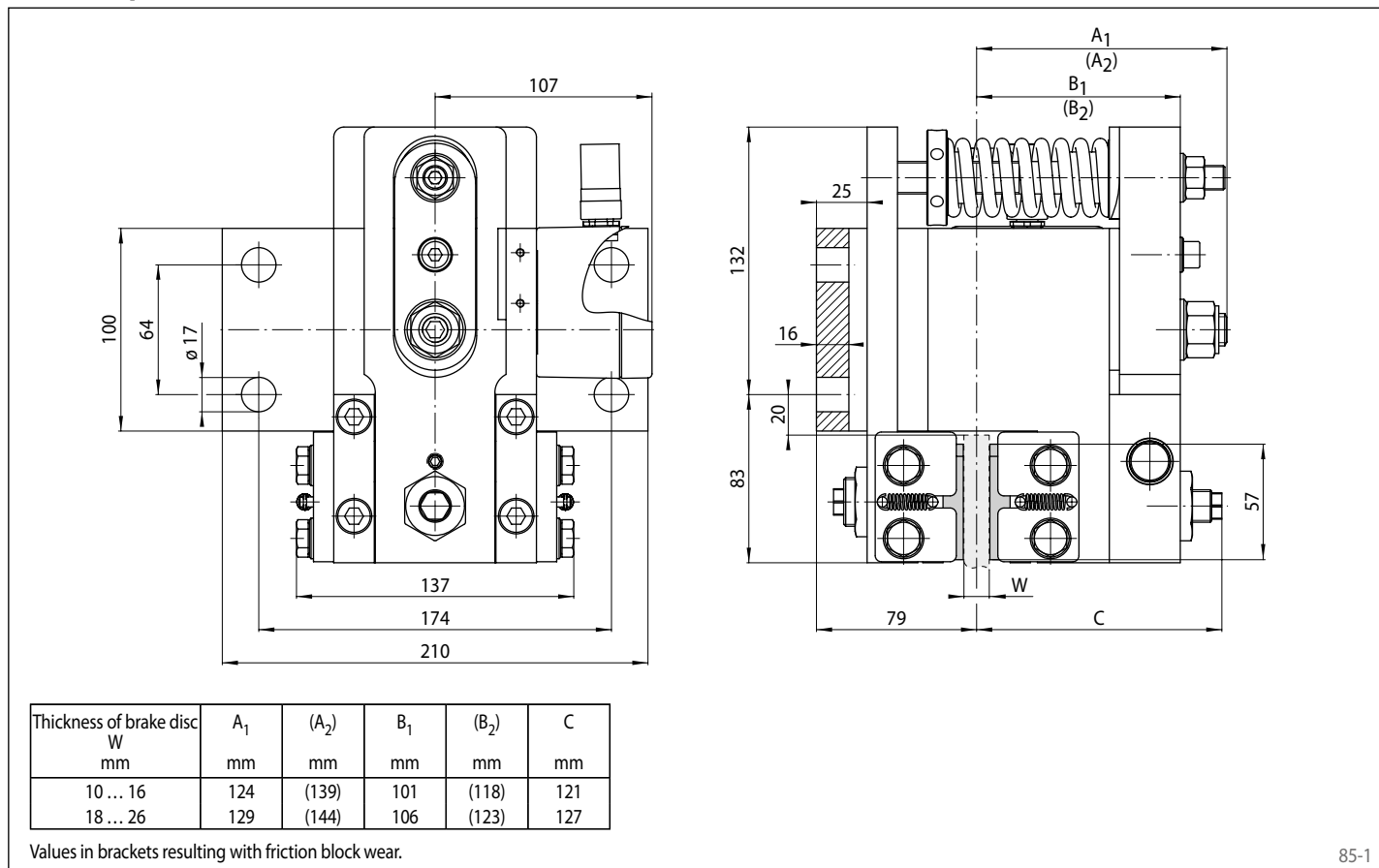

85-1

Brake Caliper EH 028 FEM

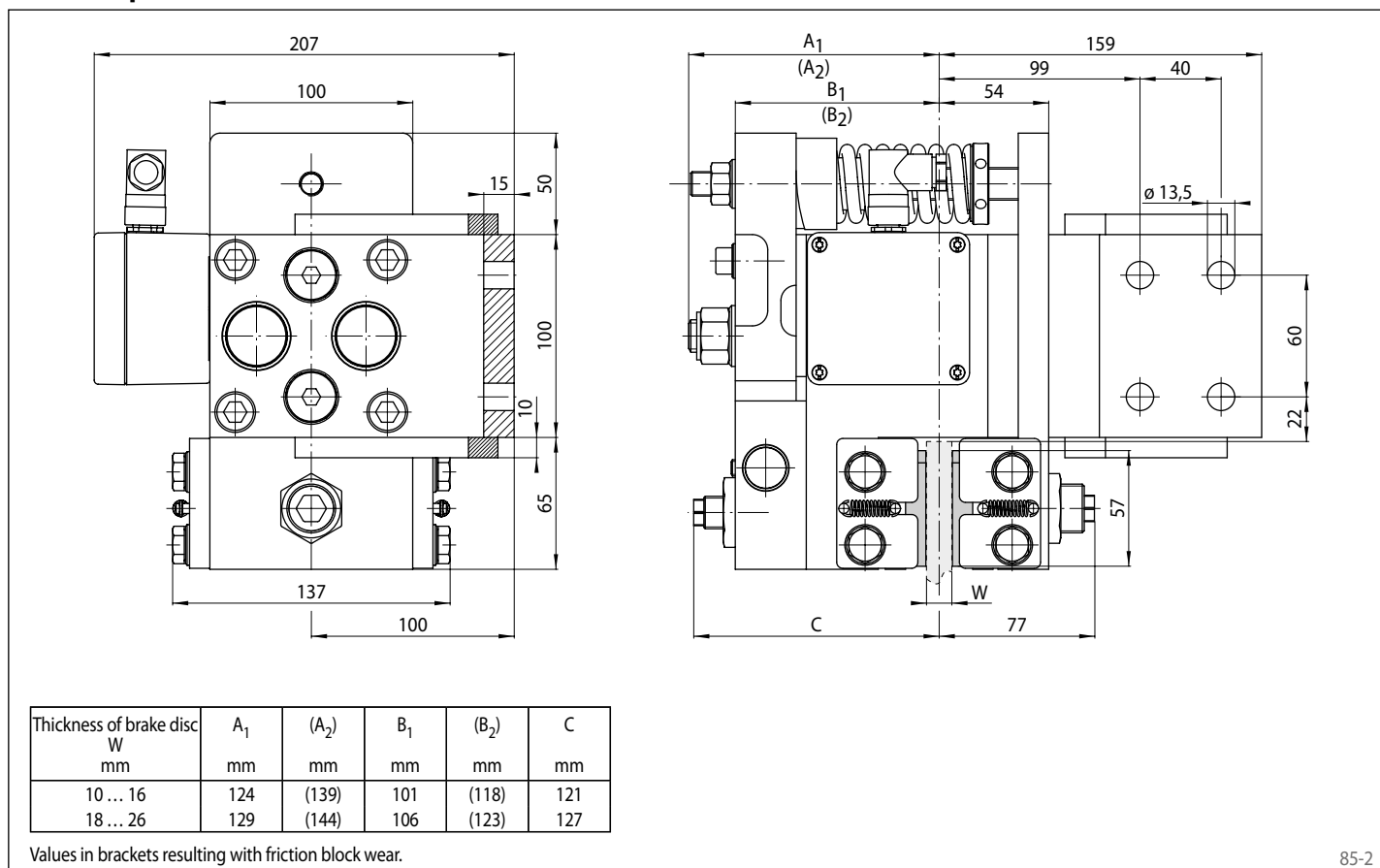

85-2