

# Brake Calipers EV 018 FEM and EH 018 FEM

spring activated – electromagnetically released

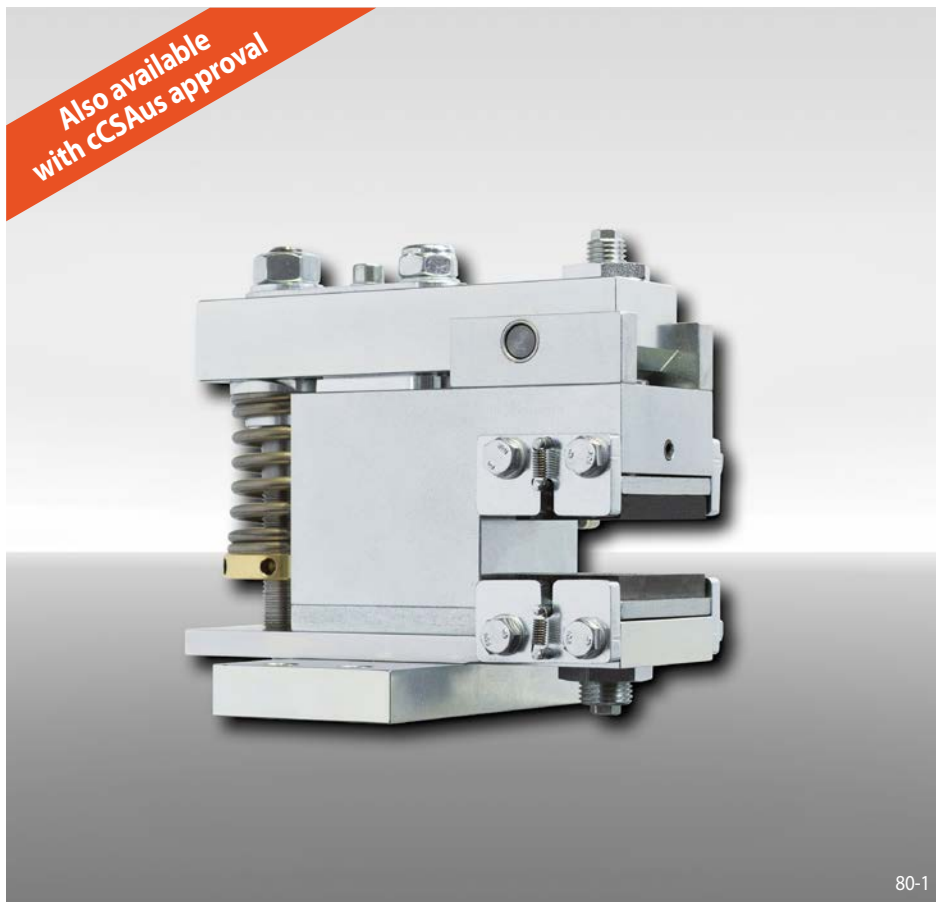

## Features

Features	Code
Brake Caliper with electromagnet	E
Mounting to the machine parallel or at right angles to the brake disc	V H
Frame size 018	018
Spring activated	F
Electromagnetically released	E
Manual adjustment to accommodate friction block wear	M
Supply voltage 220 to 240 VAC	240
Supply voltage 380 to 480 VAC	480
Electromagnet mounted in central position	M
Thickness of brake disc 8 ... 15 mm	12
or 16 ... 20 mm	20

## Example for ordering

Brake Caliper EV 018 FEM, supply voltage 400 VAC, electromagnet mounted in central position, thickness of brake disc 15 mm:

EV 018 FEM - 480 M - 12

## Advantages

The brake caliper EV 018 FEM or EH 018 FEM is a very compact and high efficient disc brake with very low power consumption. Its floating bearing compensates small misalignments of the brake disc. The separate electronic module (included) reduces the power consumption in open position automatically.

## Options

- Available with cCSAus approval
- Inductive proximity switch: "Brake released"-, "Brake closed"-status and/or "Friction block wear adjustment necessary"

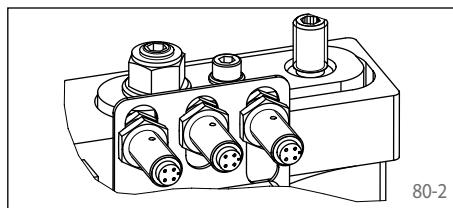

## Electronic module

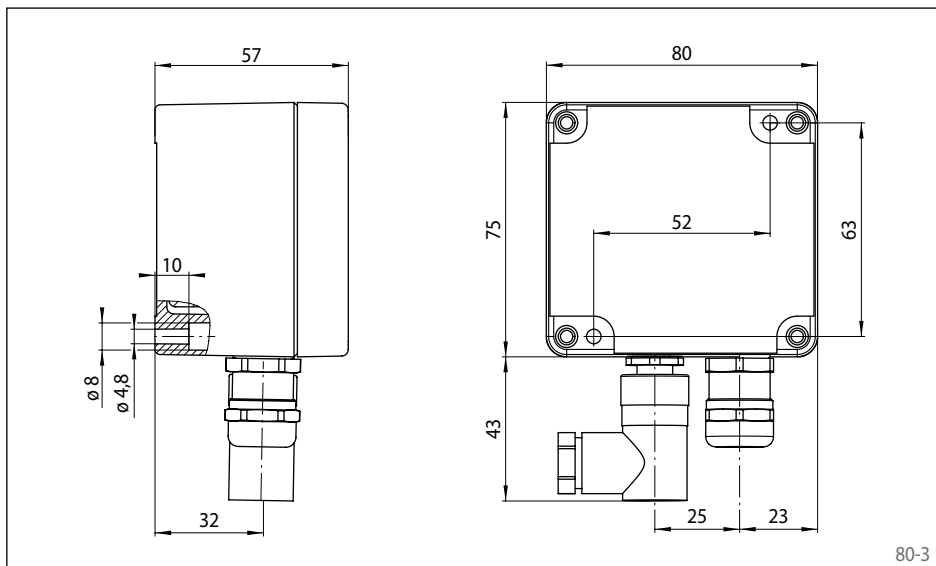

## Technical Data

	Brake Calipers EV 018 FEM and EH 018 FEM with supply voltage	
	220 to 240 VAC	380 to 480 VAC
Brake disc diameter mm		
125	100	
150	130	
200	200	
250	260	
300	320	
355	400	
Clamping force	3200 N	
Response time*	100 ms	
Clamping force or braking torque adjustable	50 - 100%	
Power consumption in open position	24 W	32 W (100% duty factor)
Power when opening the brake (< 1 s)	800 W	1200 W
Fuse rating	10 A, Type "B"	
Max. number of actuation	360/h permanent activations at 20° C ambient temperature	
Actuation frequency**	at least 8 seconds between 2 activations	
Weight	6,5 kg	

The braking torques shown in the diagram are based on a theoretical friction coefficient of 0,4.

\* The response time is the duration from switching off the power supply to reaching 80% of the maximum clamping force (at Ta = 20 °C, setting: 100%).

\*\* Shorter actuation frequency on request

# Brake Calipers EV 018 FEM and EH 018 FEM

spring activated – electromagnetically released

## Brake Caliper EV 018 FEM

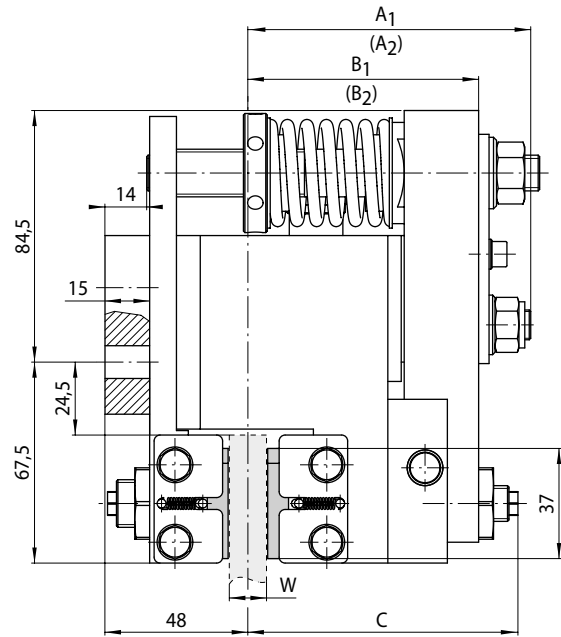
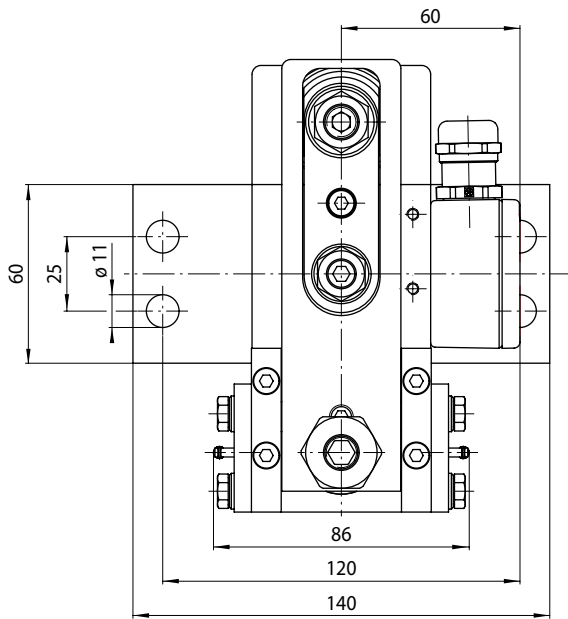

Thickness of brake disc W mm	A <sub>1</sub> mm	(A <sub>2</sub> ) mm	B <sub>1</sub> mm	(B <sub>2</sub> ) mm	C mm
8 ... 15	97	(108)	76,5	(95)	90
16 ... 20	99	(110)	78,5	(97)	94

Values in brackets resulting with friction block wear.

81-1

## Brake Caliper EH 018 FEM

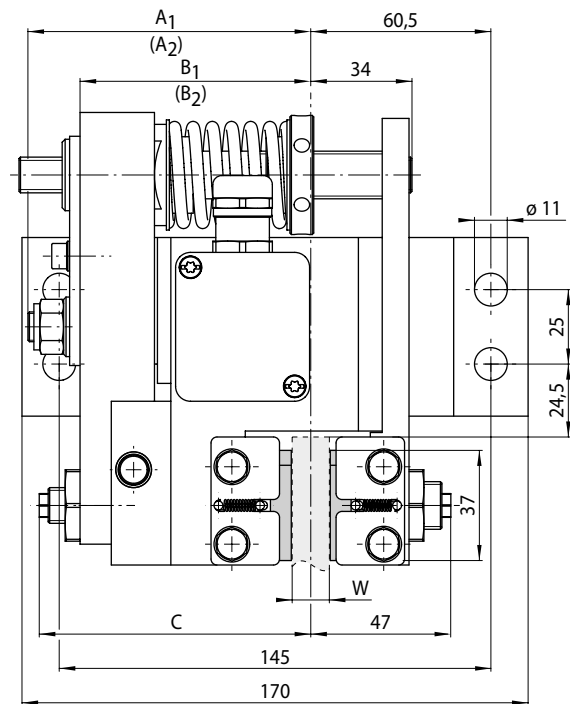
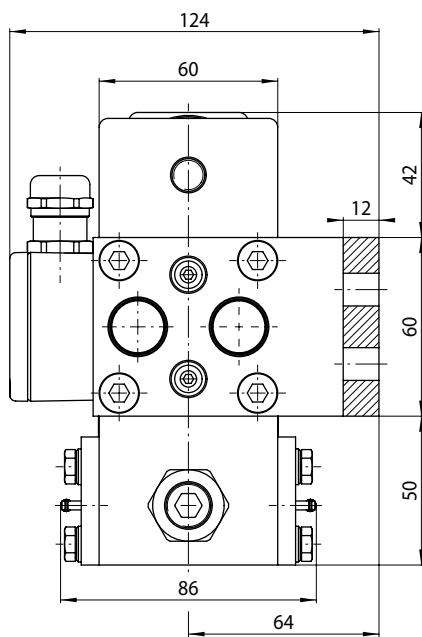

Thickness of brake disc W mm	A <sub>1</sub> mm	(A <sub>2</sub> ) mm	B <sub>1</sub> mm	(B <sub>2</sub> ) mm	C mm
8 ... 15	97	(108)	76,5	(95)	90
16 ... 20	99	(110)	78,5	(97)	94

Values in brackets resulting with friction block wear.

81-2