

Brake Caliper DS 370 FEA

spring activated – electrohydraulically released

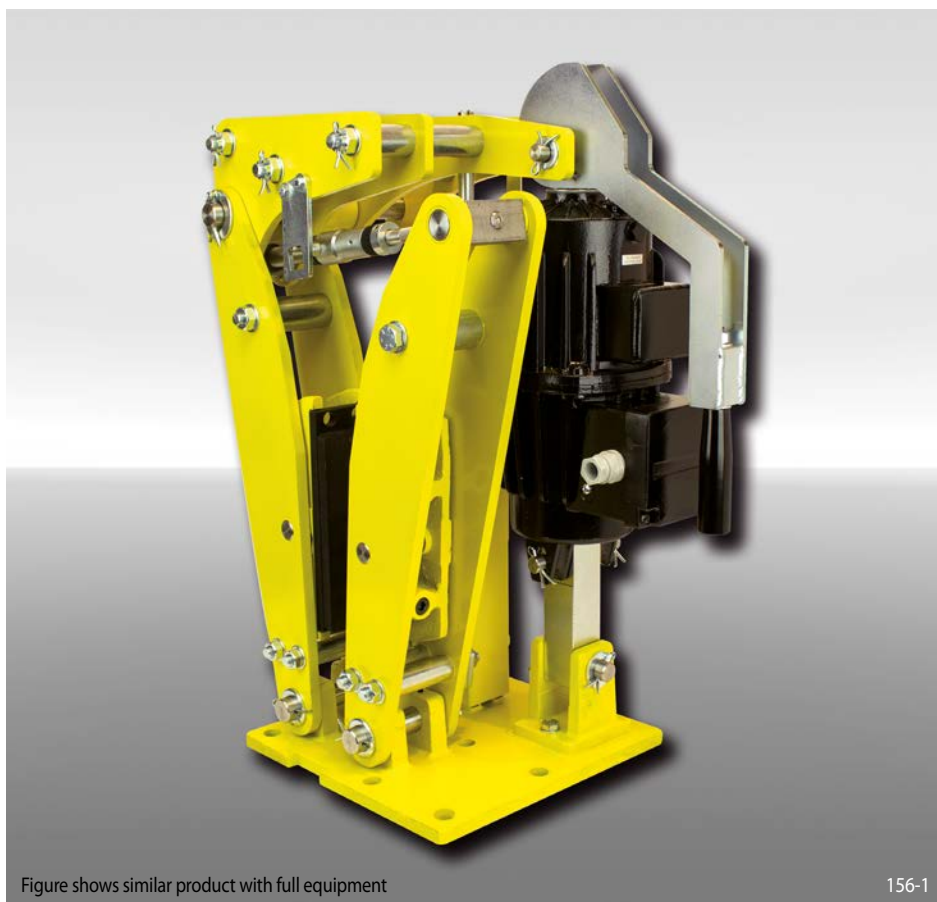

Figure shows similar product with full equipment

156-1

Features	Code
Brake Caliper	D
Disc Brake	S
Frame size 370	370
Spring activated	F
Electrohydraulically released	E
Automatic adjustment to accommodate friction block wear	A
Thrusters 455, 456 or 457 are available	455 456 457
Thruster mounted right or left available	R L
Thickness of brake disc 30 mm	30

Example for ordering

Brake Caliper DS 370 FEA, thruster 456, thruster mounted right, thickness of brake disc 30 mm:

DS 370 FEA - 456 R - 30

Technical Data

	Brake Caliper DS 370 FEA		
	with thruster 455	with thruster 456	with thruster 457
Brake disc diameter	Braking torque	Braking torque	Braking torque
mm	Nm	Nm	Nm
500	2950	5000	7400
560	3450	5800	8600
630	4000	6750	10000
710	4550	7850	11600
800	5350	9050	13400
900	6200	10400	15400
1000	7000	11750	17400
1250	9000	15000	22400
Clamping force	20100 N	33850 N	50000 N
Braking torque adjustable	20 - 100%	20 - 100%	20 - 100%
Nominal power	370 W	590 W	680 W
Oil volume	4,5 l	11 l	11 l
Voltage	230/400 V	230/400 V	230/400 V
Weight	241 kg	267 kg	267 kg

The braking torques shown in the table are based on a theoretical friction coefficient of 0,4.

Brake Caliper DS 370 FEA

spring activated – electrohydraulically released

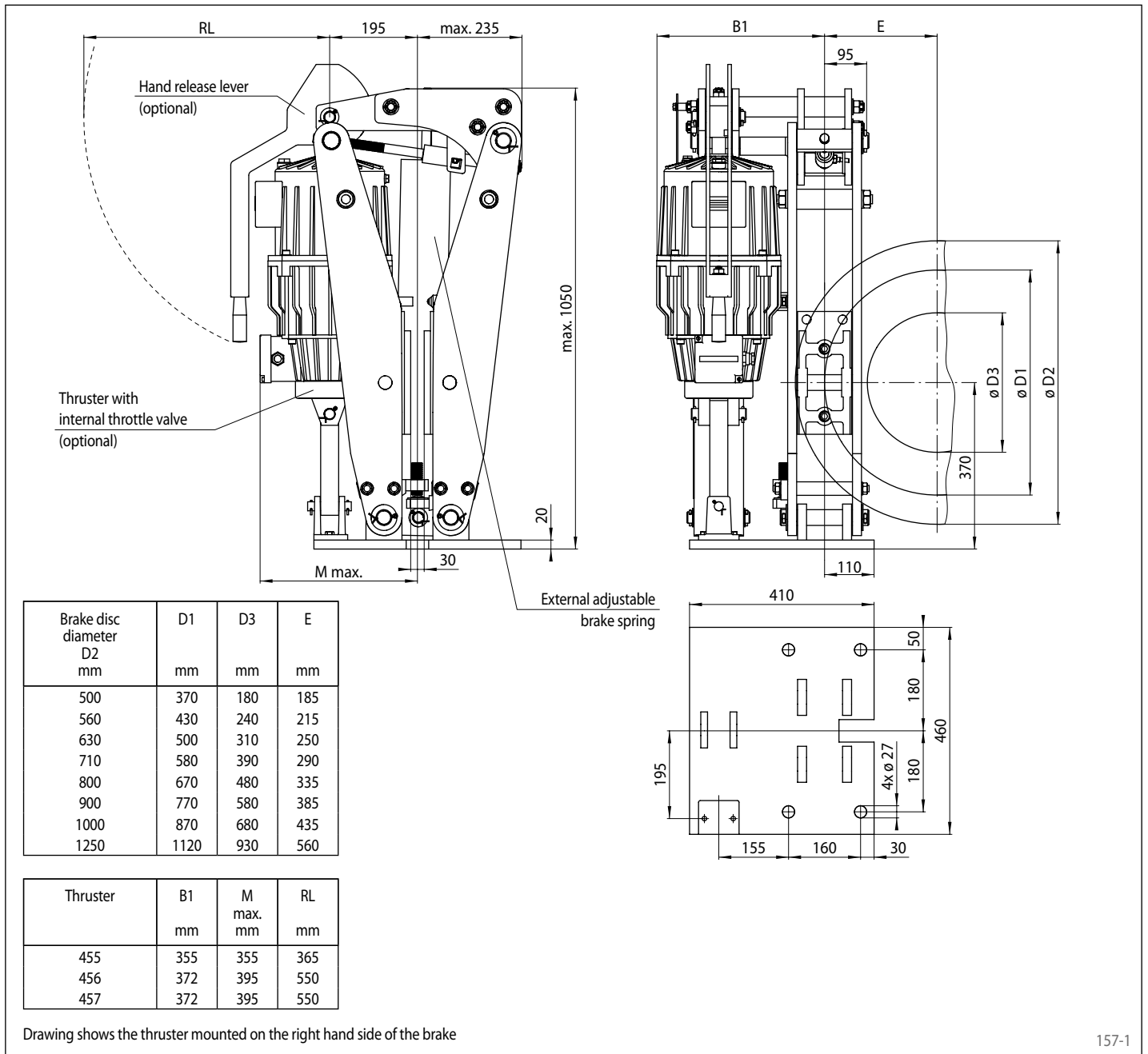

157-1

Options

- Micro-switch wear control
- Micro-switch status control
- Micro-switch residual piston stroke warning
- Hand release lever
- Hand release lever with padlock
- Thruster with internal throttle valve
- Thruster in heat resistant design
- Corrosion protected design
- Friction lining of sintered metal
- Pneumatic cylinder instead of thruster
- Thruster also available in other voltages and frequencies