

Brake Caliper DS 280 FEM

spring activated – electrohydraulically released

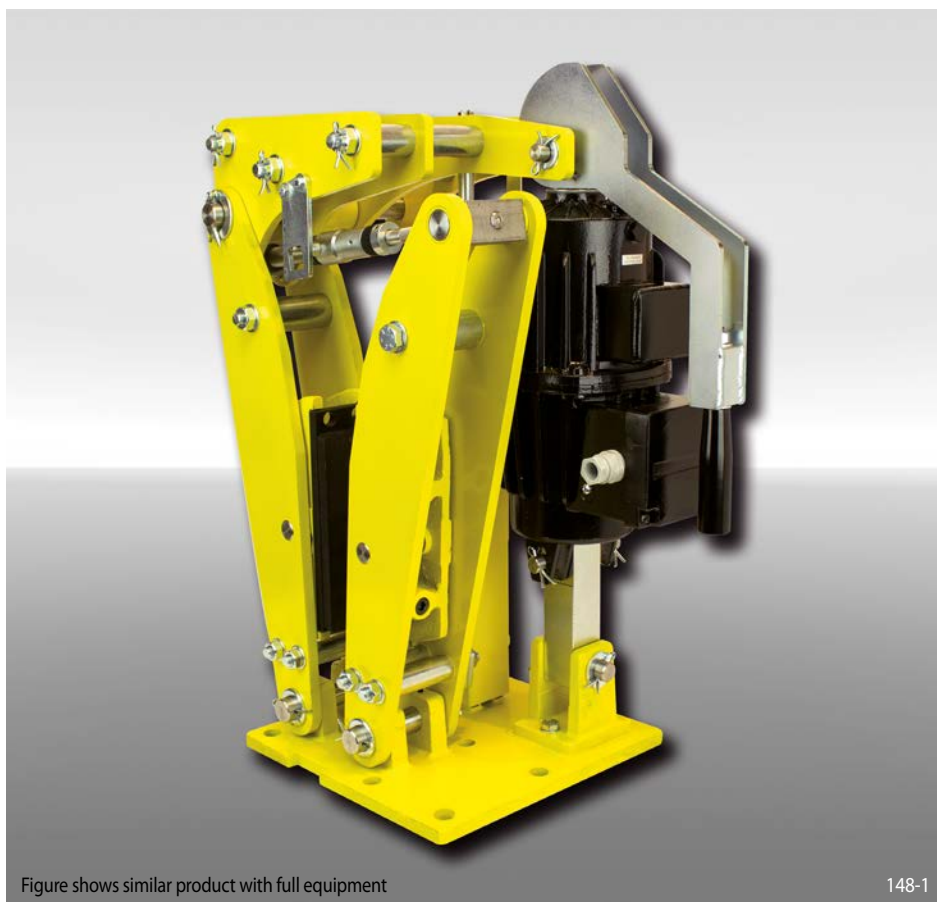

Figure shows similar product with full equipment

148-1

Features	Code
Brake Caliper	D
Disc Brake	S
Frame size 280	280
Spring activated	F
Electrohydraulically released	E
Manual adjustment to accommodate friction block wear	M
Thrusters 453, 454, 455 or 456 are available	453 to 456
Thruster mounted right or left available	R L
Thickness of brake disc 30 mm	30

Example for ordering

Brake Caliper DS 280 FEM, thruster 456, thruster mounted right, thickness of brake disc 30 mm:

DS 280 FEM - 456 R - 30

Technical Data

	Brake Caliper DS 280 FEM			
	with thruster 453	with thruster 454	with thruster 455	with thruster 456
Brake disc diameter	Braking torque	Braking torque	Braking torque	Braking torque
mm	Nm	Nm	Nm	Nm
400	1200	1450	2400	3950
450	1400	1700	2800	4650
500	1600	1950	3200	5300
560	1850	2250	3650	6100
630	2100	2600	4250	7050
710	2450	3000	4850	8100
Clamping force	10050 N	12250 N	20050 N	33250 N
Braking torque adjustable	20 - 100%	20 - 100%	20 - 100%	20 - 100%
Nominal power	240 W	280 W	370 W	590 W
Oil volume	3,5 l	3,5 l	4,5 l	11 l
Voltage	230/400 V	230/400 V	230/400 V	230/400 V
Weight	126 kg	126 kg	132 kg	158 kg

The braking torques shown in the table are based on a theoretical friction coefficient of 0,4.

Brake Caliper DS 280 FEM

spring activated – electrohydraulically released

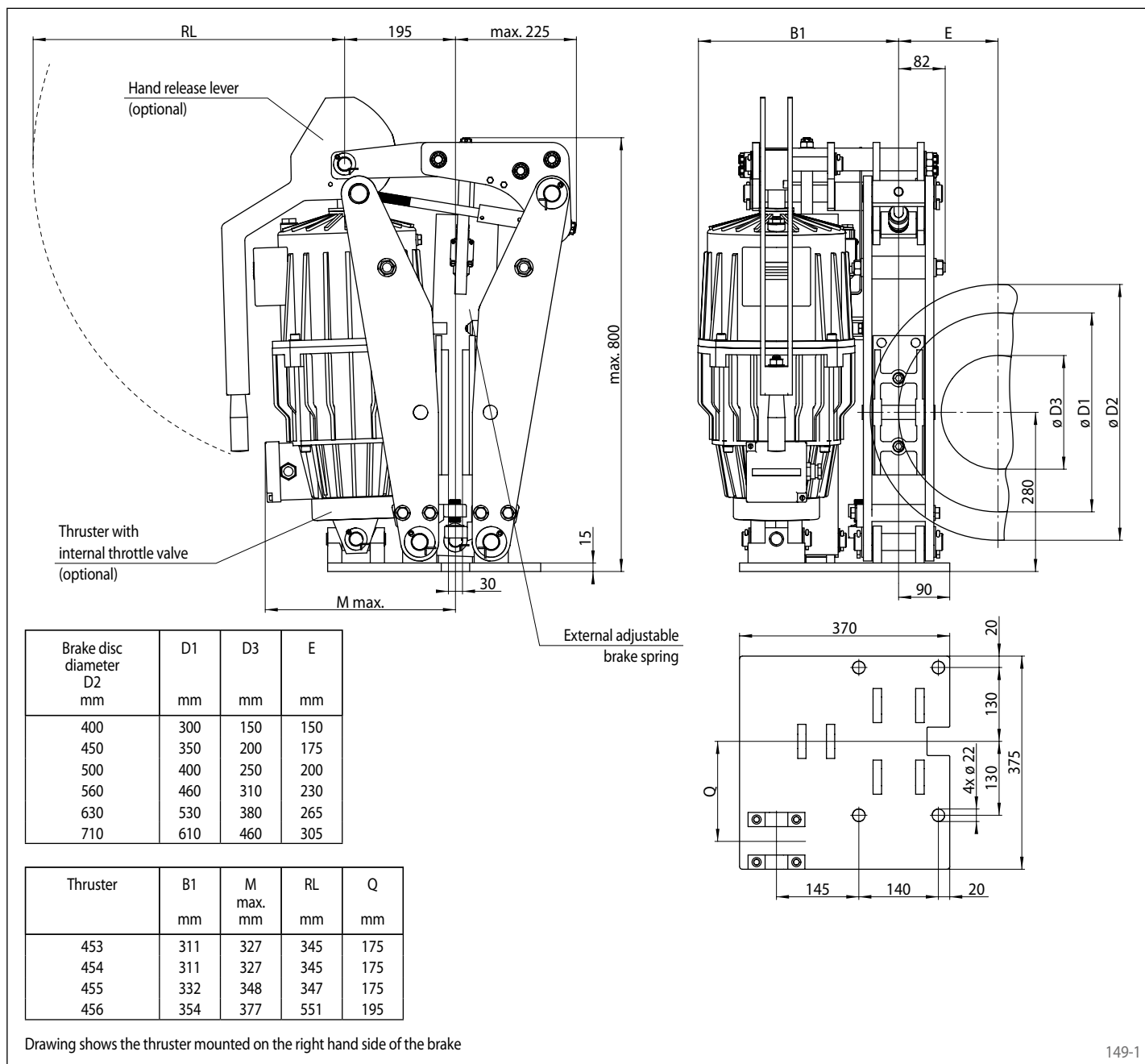

149-1

Options

- Micro-switch wear control
- Micro-switch status control
- Micro-switch residual piston stroke warning
- Hand release lever
- Hand release lever with padlock
- Thruster with internal throttle valve
- Thruster in heat resistant design
- Corrosion protected design
- Friction lining of sintered metal
- Pneumatic cylinder instead of thruster
- Thruster also available in other voltages and frequencies