

# Brake Caliper HW 120 FHM

spring activated – hydraulically released

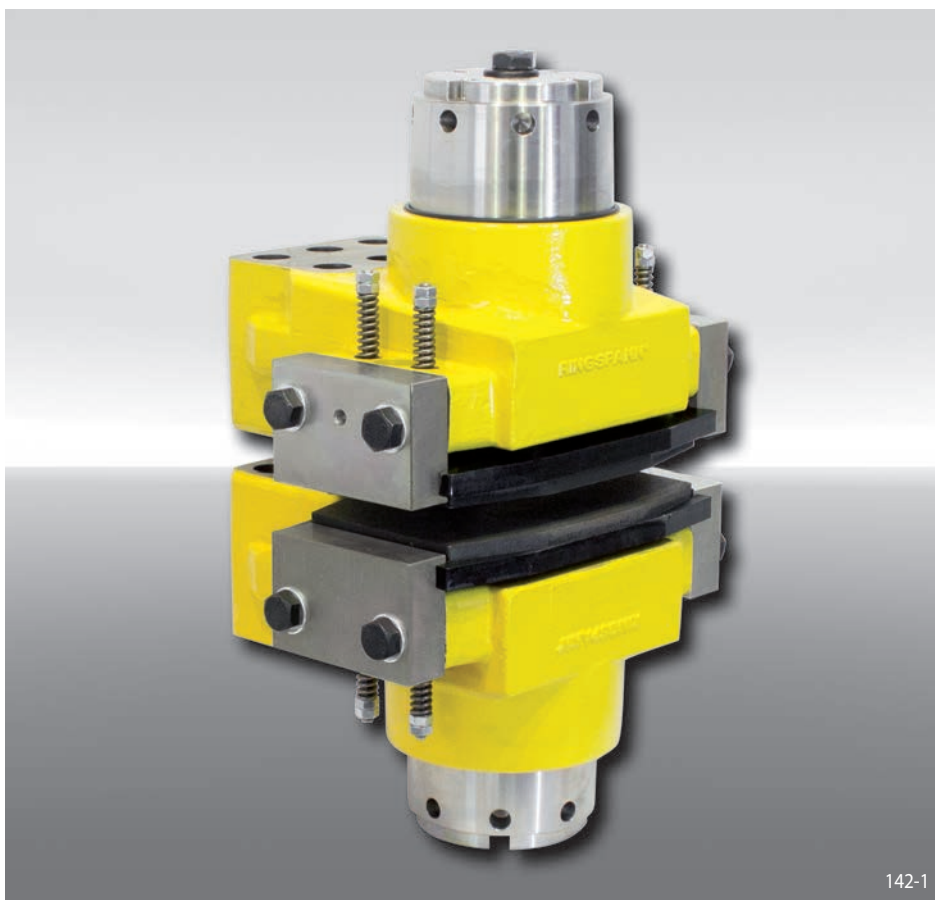

Features	Code
Brake Caliper	H
Standard	W
With piston diameter 120 mm	120
Spring activated	F
Hydraulically released	H
Manual adjustment to accommodate friction block wear	M
Spring packages available for clamping forces of 30 kN, 50 kN, 70 kN, 100 kN or 120 kN	030 to 120

### Example for ordering

Brake Caliper HW 120 FHM, spring package for clamping force 30 kN:

HW 120 FHM - 030

## Technical Data

	Brake Caliper HW 120 FHM				
	with spring package 030	with spring package 050	with spring package 070	with spring package 100	with spring package 120
Brake disc diameter	Braking torque	Braking torque	Braking torque	Braking torque	Braking torque
mm	Nm	Nm	Nm	Nm	Nm
900	8400	14000	19600	28000	33600
1250	12600	21000	29400	42000	50400
1600	16800	28000	39200	56000	67200
2000	21600	36000	50400	72000	86400
3000	33600	56000	91800	112000	134400
3500	39600	66000	108200	132000	158400
4000	45600	76000	124600	152000	182400
Clamping force	30 kN	50 kN	70 kN	100 kN	120 kN
Oil pressure	min. 50 bar max. 200 bar	min. 80 bar max. 200 bar	min. 110 bar max. 200 bar	min. 140 bar max. 200 bar	min. 180 bar max. 200 bar
Oil volume	max. 170 cm <sup>3</sup>	max. 170 cm <sup>3</sup>	max. 170 cm <sup>3</sup>	max. 170 cm <sup>3</sup>	max. 170 cm <sup>3</sup>
Weight	ca. 185 kg	ca. 185 kg	ca. 185 kg	ca. 185 kg	ca. 185 kg

The braking torques shown in the table are based on a theoretical friction coefficient of 0.4.

# Brake Caliper HW 120 FHM

spring activated – hydraulically released

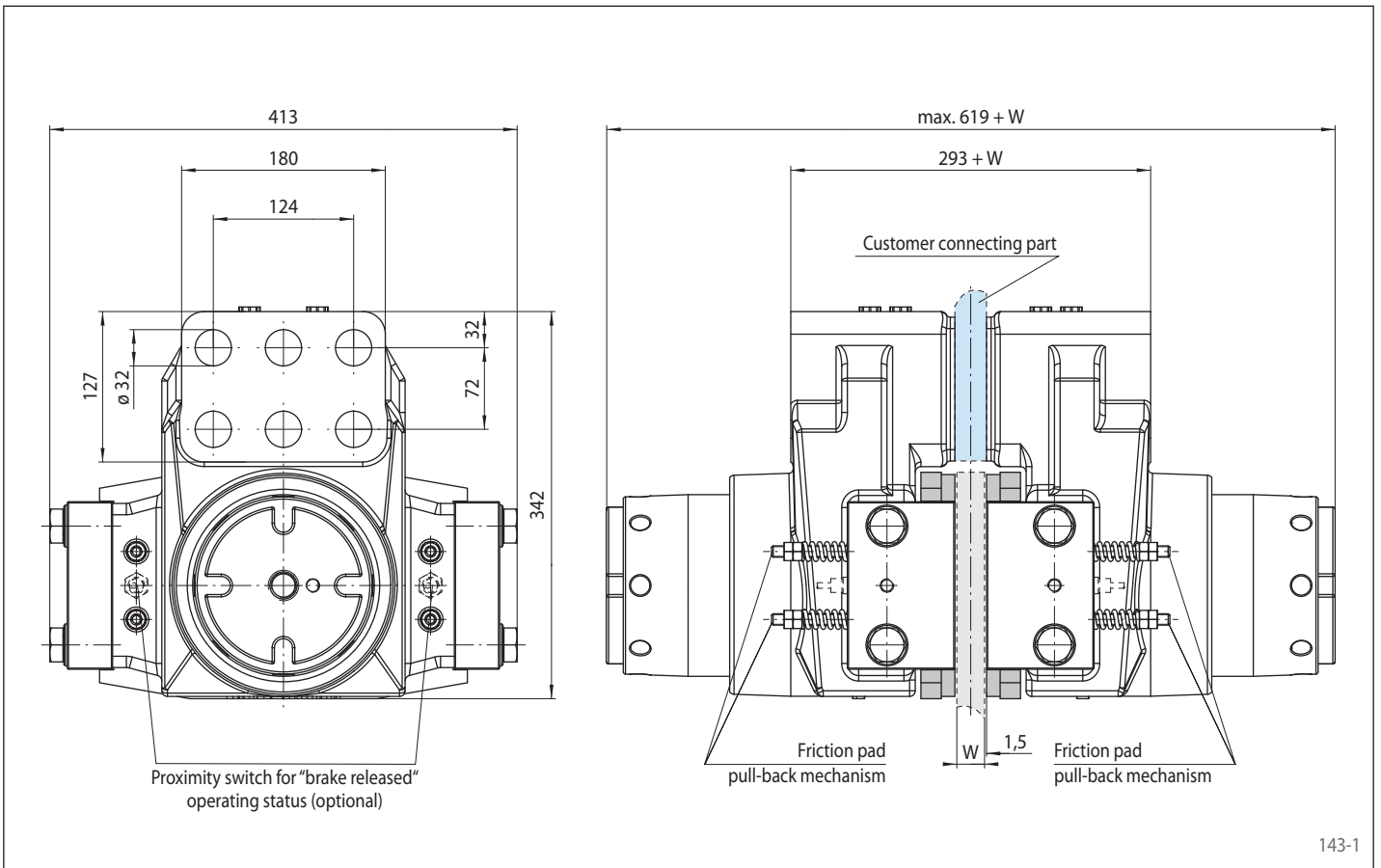

143-1

## Mounting

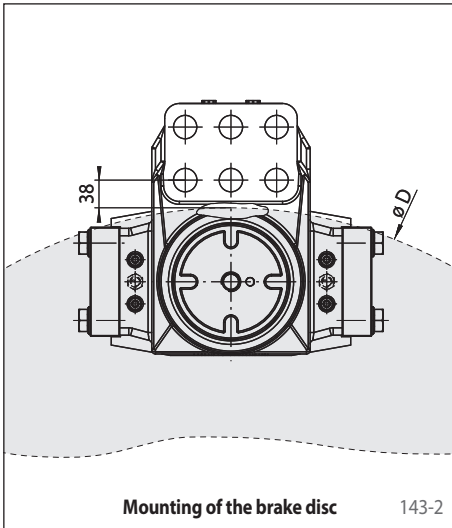

Mounting of the brake disc

143-2

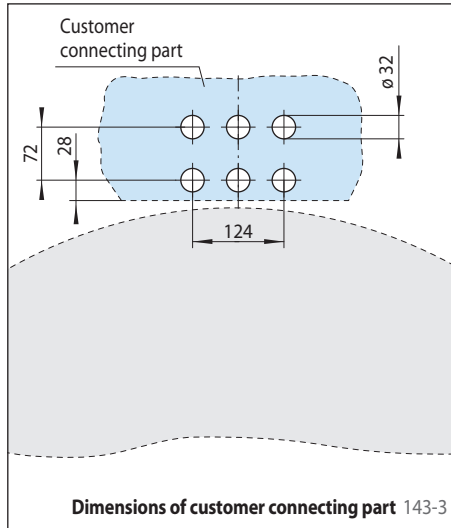

Dimensions of customer connecting part

143-3

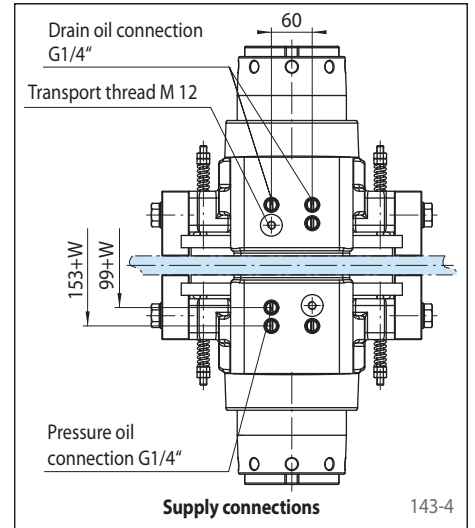

Supply connections

143-4

## Other features

- High safety against leakage
- Easy change of friction blocks
- Painted with surface coating class C4-L according to ISO 12944
- The thickness of the customer connecting part results from the thickness of the brake disc  $W$  plus 3 mm

## Accessories

- Inductive proximity switch for "brake released" operating status
- Optional painting with surface coating class C4-H or C5M-H (offshore) according to ISO 12944